

# Stay Healthy and Safe While Giving Manicures and Pedicures

*A Guide for Nail Salon Workers*



**Occupational Safety  
and Health Administration**

U.S. Department of Labor

OSHA 3542-05 2012

This booklet was adapted from *Stay Healthy and Safe While Giving Manicures and Pedicures: A Guide for Nail Salon Workers*, which was developed by the Labor Occupational Health Program (LOHP), University of California, Berkeley and the California Healthy Nail Salon Collaborative, which was produced through the Susan Harwood Grant Program, under grant number SH20864SH0 from the Occupational Safety and Health Administration, U.S. Department of Labor.

Photos and video stills were provided by the Asian Law Caucus and Street Level Health Project, the Boston Public Health Commission, and the King County Local Hazardous Waste Management Program. Illustrations were provided by Mary Ann Zapalac.

# Stay Healthy and Safe While Giving Manicures and Pedicures

## A Guide for Nail Salon Workers

U.S. Department of Labor  
Occupational Safety and Health Administration  
OSHA 3542-05 2012



U.S. Department of Labor

With this guide, you will learn about possible hazards in nail salons and good work practices that should be used in nail salons to protect you from chemical hazards, muscle strains, and diseases. This booklet also explains your rights as a nail salon worker. For more information, see OSHA's Health Hazards in Nail Salons website at [www.osha.gov](http://www.osha.gov).

# Contents

<b>Chemical Hazards</b> .....	3
Hazardous Chemicals Found in Nail Salon Products .....	3
Where to Get Information about the Chemicals Found in Nail Salon Products ...	4
Product Labels .....	4
Material Safety Data Sheets (often called “MSDSs”) .....	5
Steps You Can Take to Protect Your Health .....	5
Choose Safer Products .....	5
Ventilate the Room and Let in Fresh Air .....	6
Use Safe Work Practices to Avoid Regular and Accidental Exposures .....	7
Keep Products Off of Skin and Out of Eyes .....	7
Respiratory Protection .....	8
<b>Preventing Aches and Pains</b> .....	10
Steps You Can Take to Reduce These Hazards .....	10
Stretching Exercises You Can Do to Reduce Aches and Pains .....	11
<b>Biological Hazards</b> .....	12
Steps You Can Take to Prevent Exposure and Protect Your Health .....	12
<b>Your Rights as a Worker</b> .....	13
What is the difference between an Employee and an Independent Contractor for purposes of the Occupational Safety and Health Act? .....	13
Why does it matter? .....	13
What are my rights as a worker? .....	14
Contact OSHA .....	14
<b>For More Information</b> .....	15
Resources on Chemical Exposures in Nail Salons .....	15
Resources on How to Prevent Muscle Strains (Ergonomic Hazards) .....	16
Resources on How to Prevent Exposure to Biological Hazards .....	17
OSHA Worker Resources .....	17
NIOSH Health Hazard Evaluation Program .....	17

# Chemical Hazards

Products used in nail salons may have chemicals in them that can harm your health.

Chemicals can get into your body if you:

- Breathe in vapors, dusts, or mists from the products;
- Get the product on your skin or in your eyes; or
- Swallow the product if it gets on your uncovered food, drink, or cigarettes.

Chemicals affect different people in different ways. How a chemical affects you also depends on how much of it you are exposed to. You can get sick right away, or you can get sick over time. Exposures can “add up,” especially when many products are being used at the same time, when the products are used day after day, or when there is poor ventilation in the salon. If you use chemicals all day, every day, you are more likely to get sick than someone who uses the same chemicals once in a while. Follow the steps in this guide to help protect your health.

## Hazardous Chemicals Found in Nail Salon Products

Nail products, such as polishes, strengtheners, removers, and artificial nail liquids, can contain many chemicals. Some of these chemicals are more harmful than others. Over time with repeated use or exposure to high concentrations, these chemicals could damage your body or cause an allergic reaction. Every person is different and not everyone who breathes in these chemicals or gets them on their skin will experience these effects now or in the future.

Some potentially hazardous chemicals, the types of products they can be found in, and how they can affect your body include:

- Acetone (nail polish remover): headaches; dizziness; and irritated eyes, skin, and throat.
- Acetonitrile (fingernail glue remover): irritated nose and throat; breathing problems; nausea; vomiting; weakness; and exhaustion.
- Butyl acetate (nail polish, nail polish remover): headaches and irritated eyes, skin, nose, mouth, and throat.
- Dibutyl phthalate (DBP) (nail polish): nausea and irritated eyes, skin, nose, mouth, and throat. Long-term exposures to high concentrations may cause other serious effects.
- Ethyl acetate (nail polish, nail polish remover, fingernail glue): irritated eyes, stomach, skin, nose, mouth, and throat; high concentrations can cause fainting.



### Tip:

Make sure your doctor or healthcare provider knows what type of work you do and the chemicals you use. Tell them if you are pregnant or planning to become pregnant.



- Ethyl methacrylate (EMA) (artificial nail liquid): asthma; irritated eyes, skin, nose, and mouth; difficulty concentrating. Exposures while pregnant may affect your child.
- Formaldehyde (nail polish, nail hardener): difficulty breathing, including coughing, asthma-like attacks, and wheezing; allergic reactions; irritated eyes, skin, and throat. Formaldehyde can cause cancer.
- Isopropyl acetate (nail polish, nail polish remover): sleepiness, and irritated eyes, nose, and throat.
- Methacrylic acid (nail primer): skin burns and irritated eyes, skin, nose, mouth, and throat. At higher concentrations, this chemical can cause difficulty breathing.
- Methyl methacrylate (MMA) (artificial nail products, though banned for use in many states): asthma; irritated eyes, skin, nose, and mouth; difficulty concentrating; loss of smell.
- Quaternary ammonium compounds (disinfectants): irritated skin and nose and may cause asthma.
- Toluene (nail polish, fingernail glue): dry or cracked skin; headaches, dizziness, and numbness; irritated eyes, nose, throat, and lungs; damage to liver and kidneys; and harm to unborn children during pregnancy.

Report any health problems you think are from the products you use in the workplace to your employer and doctor. Employers must follow up on reports of health problems from workers.

### Where to Get Information about the Chemicals Found in Nail Salon Products

You can get product information on packaging, or in printed materials delivered with the product such as its material safety data sheet.

#### Product Labels

At minimum, professional-use nail salon products containing hazardous chemicals must provide the following information:

- The name and address of the product manufacturer or distributor;
- Something that explains the type and use of the product, such as a name, description, or illustration;
- Facts about the product, such as directions for safe use if a product could be unsafe if used incorrectly; and
- All necessary warning and caution statements.



## Material Safety Data Sheets (often called “MSDSs”)

OSHA requires product manufacturers to provide salon owners with material safety data sheets (MSDSs)<sup>1</sup> for the products they buy that contain hazardous chemicals. Employers must make these MSDSs available to you. Your employer must also train you so that you understand the chemicals’ potential hazards and how to use the products safely. In general, an MSDS must provide the following information:

- Hazardous ingredients in the product;
- How you can be exposed to the ingredients;
- Health and safety risks you face when using the product; and
- Steps for safely using and storing the product, including what to do in emergencies.

OSHA recently updated its rules about safety data sheet requirements. “Material Safety Data Sheets” will now be called “Safety Data Sheets” (SDSs). SDSs will generally list the same information as MSDSs, but all information will now be presented in a common format across products. This can help you compare the differences in hazards between products.

Be aware that MSDSs may not contain all the information needed to help protect you. For example, the manufacturer may state that you should wear “impervious gloves,” but not specify the type.

## Steps You Can Take to Protect Your Health

### Choose Safer Products

- Whenever possible, use products with the least hazardous chemicals in them.
  - 3-free: Some products now claim to be made without the “toxic trio” (toluene, formaldehyde, and dibutyl phthalate). These products are called “3-free” products.<sup>2</sup>
  - Acid free: Some primers claim to be made without chemicals like methacrylic acid. These are labeled “acid free.”
- Always read product labels and MSDSs and follow manufacturers’ instructions when using all nail salon products, including those labeled as “free” of hazardous chemicals.

<sup>1</sup> OSHA’s Hazard Communication standard, 29 CFR 1910.1200.

<sup>2</sup> On April 10, 2012 the California Department of Toxic Substances (DTSC) announced its discovery of certain nail polish and nail care products that may endanger nail salon workers and the public despite being marketed as non-toxic. In May 2011, DTSC tested 25 nail products sold by California distributors. Of the 12 claiming to be “toxic-free,” 10 contained toluene and four contained dibutyl phthalate (DBP). For more information, call (800) 728-6942 or visit [www.dtsc.ca.gov](http://www.dtsc.ca.gov).



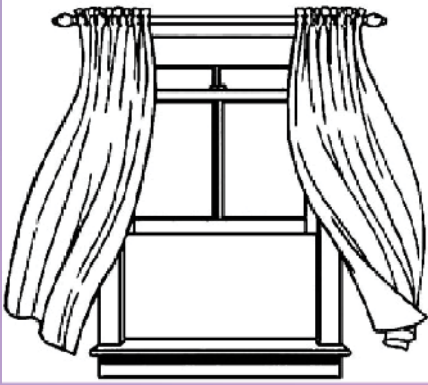

## Ventilate the Room and Let in Fresh Air

Ventilation is the best way to lower the level of chemicals in the salon. These steps can really help improve your health:

- Open doors and windows when possible to let in fresh air. If the salon has a ceiling vent, it should be turned on and working.
- Always keep the nail salon's exhaust system on.
- If your salon does not have an exhaust system, always keep the heating, ventilation, and air conditioning (HVAC) system on during work hours. The HVAC thermostat fan switch should always be in the "on" position (not "auto") so that it runs even when the heat or air conditioner is off. The salon owner should have a HVAC contractor clean the HVAC system and replace the filters at least once a year.
- Place fans near open doors or windows. Fans should pull air in one end of the salon and push it out of the other end.



Bad ventilation: Outside air from the open window blows the chemicals into the worker's face before being vented out of the salon.

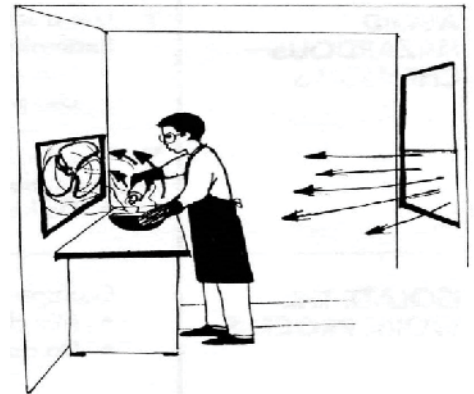

Good ventilation: Outside air from the open window blows the chemicals away from the worker's face before being vented out of the salon.



Some manicure tables are made with ventilation systems built into them.

Photo of ventilated table courtesy of the Boston Public Health Commission.

- If the salon has ventilated tables:
  - Make sure they are turned on.
  - Change the charcoal filters at least once a month.
  - Clean out the catch basin at least once a week.
- If the salon has portable ventilation machines, use them in your work area to pull harmful vapors away from you and your clients.



## Use Safe Work Practices to Avoid Regular and Accidental Exposures

- Store chemicals in small bottles with small openings and label them with the information from the manufacturer's label.
- Close bottles tightly when you are not using them so the product does not spill or get into the air.
- Use metal trashcans with tight, self-closing lids to keep the nail products soaked on cotton balls and other trash from evaporating and getting into the salon's air.
  - Put cotton balls and other soaked materials into the trashcans immediately.
  - If you do not have metal trashcans with self-closing lids, put cotton balls and soaked materials in a sealed bag before putting them in the trashcan and keep the trash covered.
  - Empty trashcans often and remove from the work area to the outside garbage at the end of each day.
- Use only the amount of product you need to perform services. When possible, do not keep extra products at a workstation.
- Follow instructions for safely disposing of used chemicals. DO NOT pour them down your sink or toilet, throw them on the ground or down outside drains, or pour them onto cotton balls.
  - Some chemicals must be disposed of in a specific way. For example, used liquid acetone must be saved in a fire department-approved metal container and disposed of as hazardous waste.
- Wash your hands before eating, drinking, putting on cosmetics, and smoking.
- When you have a break, go outside to get some fresh air. This will give you a chance to get away from chemicals in the salon's air.
- Keep food and drinks covered at all times, and do not store or eat food in work areas.

## Keep Products Off of Skin and Out of Eyes

- Wear long-sleeved shirts to protect your arms and pants or skirts that are at least knee-length to protect your lap from acrylic nail and other dusts.
- Wash your hands before and after working on clients; before eating, drinking, putting on cosmetics or smoking; and after handling or transferring products.
- Wear goggles and the appropriate type of disposable gloves when handling and transferring products. For example, nitrile gloves (usually blue or purple) protect against many chemicals used in nail salon products, but latex or vinyl gloves are appropriate when handling acetone.



Ventilation off: Without a ventilation system running, chemical levels during acrylic nail removal reached very high levels (over 826 parts per million).



Ventilation on: With a ventilation system running, chemical levels dropped significantly during the same process (below 12.4 parts per million).

Images courtesy of the Local Hazardous Waste Management Program in King County, WA.



- Replace gloves immediately if there are cuts, tears, or holes in them.
- Cover and protect cuts or cracks in your skin. Damaged skin can increase chemical absorption and exposure.
- Do not continue to use a product if you see signs of skin irritation.
  - If your hands are red and irritated, make sure your gloves are the right type for the product you are using.

## Respiratory Protection

Using the ventilation methods described above, using products without harmful chemicals, and following good work practices all reduce the level of chemicals in a nail salon. If you work in a salon that follows these practices, you may not need respiratory protection.

### Evaluating Possible Hazards

Employers need to determine if the levels of dust and/ or chemical vapors in the salon pose a risk to workers and decide if respirators are required. Small employers can use available industrial hygiene services from OSHA's On-site Consultation Program. Other groups that can provide assistance include an employer's private insurance company or private industrial hygiene consulting firms.

Because chemicals can cause effects even at low levels, you may decide that you want to wear a respirator to protect yourself while transferring chemicals or when buffing and filing nails.

### Types of Respirators

Many nail salon workers wear paper or cloth medical masks. These are not the same as dust masks (filtering facepieces), and even when stuffed with tissues, they will not protect you from breathing in harmful gases, vapors, or dusts.

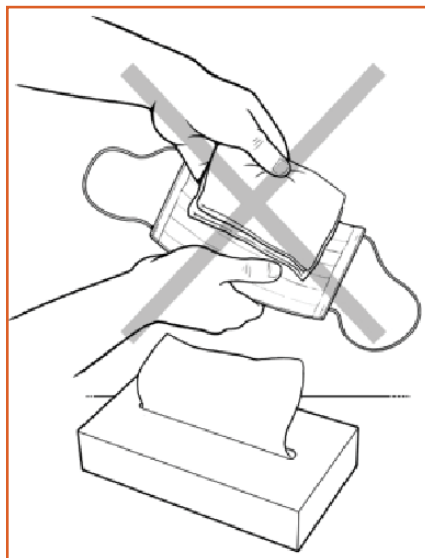

Here are some types of respirators that may be used in nail salons:

### Filtering Facepiece Respirators (Dust Masks)

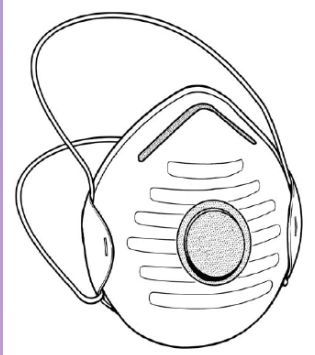

You should only use NIOSH-approved filtering facepiece respirators. “N95s” are one type.

This type of respirator will:

- Help protect you from dust, viruses, and germs.

This type of respirator will not:

- Protect you from vapors or gases. Some N95s have filters that reduce chemical odors, but they may not protect you from harmful chemical exposure levels.

Filtering facepiece respirators may be helpful when you are:

- Buffing or filing artificial nails; or
- Using acrylic powders.

You don't need to wear the mask all the time, only when you are working on a client. When you put on this mask, make sure your hands are clean to avoid irritating your skin.

If your employer allows you to wear this type of respirator voluntarily, then he/ she must give you Appendix D of the OSHA Respiratory Protection Standard, which explains some important information about how to safely and effectively use your respirator.

### Half-mask Respirators with Cartridges



Half-mask respirators with chemical cartridges offer protection from breathing in chemical vapors.

This type of respirator will:

- Help protect you from breathing in chemical gases and vapors (such as formaldehyde).

Your employer may require you to wear this type of respirator when you:

- Transfer chemicals from larger bottles to smaller bottles; or
- Clean up large spills.

If you must use this type of respirator:

- Your employer is required to develop a respiratory protection program;
- You must be fitted and trained to wear a respirator properly;
- Your employer must evaluate the appropriate cartridge for the job task and provide it to you; and
- You must know how and when to change cartridges, and your employer must provide you with a cartridge change out schedule.

# Preventing Aches and Pains

Nail salon workers can get aches and pains from leaning over a worktable for a long time; doing repetitive movements like filing and buffing nails; and resting hands, wrists, and forearms and/or elbows against hard surfaces or sharp edges of worktables. These are often called ergonomic or musculoskeletal hazards because they affect your muscles and bones. Ergonomics is the science of “fitting the task to the worker” so that you are more comfortable and efficient when doing your job. Good ergonomic practices will reduce stress to your body and help you avoid aches and pains.

## Steps You Can Take to Reduce These Hazards

- Use an adjustable chair. Sit so that your feet are flat on the floor and your back is supported. Use a footrest if your feet do not touch the floor when sitting.
- Make sure there is enough space between the back of your knees and the front edge of your seat to improve blood flow to your legs.
- Adjust the lighting. Good lighting can help you see without having to bend over.
- Raise the client’s hand or foot. Use a cushion to raise the client’s hand or foot so you do not have to bend over as far.
- Use safety glasses with magnifying lenses. These glasses reduce the need for you to bend over to see the client’s hand or foot.
- Put a towel or foam pad on the table edge to soften it for hands, arms, wrists, and elbows.
- Put soft pads on tools to make handles larger and easier to hold.
- Take frequent breaks if possible; changing positions and doing a different task is also helpful.
- Pace your work. When you work too fast, your body can become tense, which could cause muscle pain.
- Do gentle stretching exercises, like the ones on the following page, in between sessions with clients. You may need to check with your doctor first!

What is wrong with this picture?



What improvements do you see?



## Stretching Exercises You Can Do to Reduce Aches and Pains



- Neck: Keeping your arms and shoulders loose:
- Tilt your head to one side for 2 seconds.
  - Tilt your head to the other side for 2 seconds.



- Fingers: Stretch your fingers out and hold for 8 seconds. Relax.
- Make a claw with your hands and hold for 8 seconds. Relax.



- Shoulders and Upper Back: Put one hand on your shoulder and look the opposite way. Pull your elbow in and up with the other hand.
- Hold for 2 seconds.



- Lower Back and Hips: Lean forward keeping your neck relaxed and your head down.
- Hold for 8 seconds while breathing slowly.
- Use your hands to push yourself up.



- Neck: Keeping your arms and shoulders loose and your head facing straight forward:
- Tuck your chin for 2 seconds.



- Back of Legs: Place your hands shoulder width apart on a wall or table.
- Bend your knees, keep hips directly above your feet, and lower head between arms.



- Neck: Keeping your arms and shoulders loose:
- Turn your head to one side for 2 seconds.
  - Turn your head to the other side for 2 seconds.



- Inner Thighs: With your feet wide apart, place both hands on your left knee. Bend the knee until you can feel the stretch.
- Hold for 8 seconds.



- Shoulders: Lace your fingers and stretch your arms with your palms facing out:
- Hold for 2 seconds.



- Ankles: While holding onto a table or wall for balance, put one foot out and:
- Point your toe up and down.
  - Draw circles with your foot.

# Biological Hazards

Biological hazards include bacteria, fungi, and viruses.<sup>3</sup> You can be exposed to many infectious agents, such as hepatitis B, hepatitis C, and human immunodeficiency virus (HIV), if you come into contact with infected blood from a coworker or client. You can also be exposed to fungal infections of the nails and feet by touching a client's infected skin or by using equipment that has not been cleaned.

## Steps You Can Take to Prevent Exposure and Protect Your Health

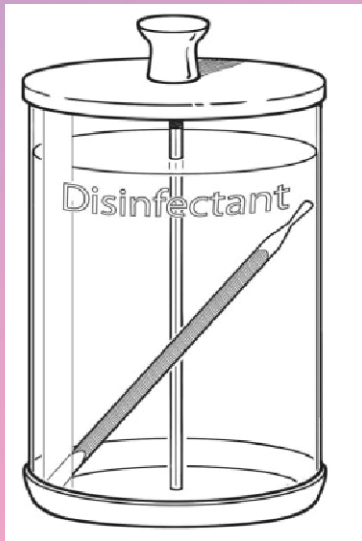

- Avoid touching any blood or bodily fluids.
- Wear gloves, and avoid clients with cuts, open wounds/ sores, blisters, or visibly infected skin on their hands, feet, or nails. Many agencies, such as the Boston Public Health Commission and the California Board of Barbering and Cosmetology, prohibit working on clients with these health issues.
- Throw away disposable gloves immediately after using them.
- Always wash your hands with soap and water before and after working with clients to avoid spreading germs.
- Bandage open cuts or broken skin to prevent contact with blood or other potentially infectious materials from a client or coworker.
- If an individual is bleeding, do not touch the blood. Ask the individual to use a cotton ball or tissue to stop the bleeding and to throw the used material directly into the trash once the bleeding has stopped.
- Consider getting immunized against hepatitis B. Your doctor can help you determine whether this is needed. Immunization practices can vary by state, so be sure to follow your state's requirements. Your employer must offer you hepatitis B immunization without charge if you are likely to be exposed to blood or other infectious materials during your work.
- Clean and disinfect tools after each client according to the policies of your state's cosmetology board. Some common steps for cleaning and disinfecting tools are:
  - Always wear the right gloves for the product you are using while cleaning and handling disinfectants or tools soaked in disinfectant.

<sup>3</sup> OSHA's Bloodborne Pathogens standard, 29 CFR 1910.1030, requires your employer to evaluate whether you may come into contact with blood or other potentially infectious material. If this risk exists, then the employer must follow the requirements of the standard, including providing training, vaccination, and personal protective equipment.

- Wash tools with soap and water. Use a scrub if needed.
- Soak tools in an EPA-registered disinfectant for 10–30 minutes, according to manufacturer directions. Follow the manufacturer’s instructions when mixing the product ratios.
- Rinse tools in clean water.
- Dry tools with a clean cloth.
- Store all disinfected tools in a clean, covered area. Only use ultraviolet (UV) sanitizing boxes to store clean and disinfected reusable metal tools. The UV boxes do not disinfect tools.
- Disinfect foot basins and spas after each client and at the end of the day. Follow your state cosmetology board’s rules on how to clean and disinfect foot basins and spas.

## Your Rights as a Worker

What is the difference between an Employee and an Independent Contractor for purposes of the Occupational Safety and Health Act?

- It doesn’t matter how an individual is labeled by the salon owner. Instead, courts and agencies will look at a list of factors to determine whether you are an employee or an independent contractor.
- For example, if you: rent a station at a salon; purchase your own supplies and tools; have your own customers and set your own schedule and appointments; set your own rate and are paid by customers directly; and have your own business license, you may be more likely to be considered an independent contractor.
- However, if: the owner sets your work schedule; you are paid by the hour; the owner or receptionist makes the appointments for all the workers; you do not rent the space; the owner sets the rates paid by customers; and you use the owner’s tools and equipment, you may be more likely to be considered an employee.

Why does it matter?

- Employers must provide protection against workplace hazards for their employees; independent contractors are responsible for their own occupational health and safety protection. Employees also have rights to a minimum wage, workers’ compensation, and other benefits. Independent contractors do not.
- Just because a salon owner tells you that you are an independent contractor, it does not mean that you are one. Just because an owner gives you an IRS form 1099 instead of a W-2 does not

mean that you are an independent contractor. Salons sometimes misclassify the employment status of their workers to bypass taking protective safety and health measures, and to also deny benefits. That is why it is important for you to know the difference between what constitutes an employee and an independent contractor. If you need help, you can contact OSHA at 1-800-321-OSHA (6742).

## What are my rights as a worker?

You have the right to working conditions that do not put you at risk of serious harm. OSHA also provides you with the right to:

- Ask OSHA to inspect your workplace;
- Receive information and training about hazards, methods to prevent harm, and the OSHA standards that apply to your workplace. The training must be in a language you can understand;
- Get copies of test results done to find and measure hazards in your workplace;
- Review records of work-related injuries and illnesses;
- Get copies of your medical records;
- File a complaint asking OSHA to inspect your workplace if you believe there is a serious hazard or that your employer is not following the OSHA rules. When requested, OSHA will keep all identities confidential; and
- Use your rights under the law without retaliation or discrimination. Your employer cannot fire or punish you if you file a complaint.

For more information on workers' rights, employer responsibilities, and other OSHA services, visit OSHA's website at [www.osha.gov](http://www.osha.gov) and OSHA's Workers page at [www.osha.gov/workers.html](http://www.osha.gov/workers.html).

## Contact OSHA

For questions or to get information or advice, report an emergency, fatality or catastrophe, order publications, file a complaint, or request OSHA's Free On-Site Consultation Program, contact your nearest office through OSHA's website at [www.osha.gov](http://www.osha.gov), or call 1-800-321-OSHA (6742); TTY 1-877-889-5627. We will keep your information confidential. We are here to help you.

Twenty-five states, Puerto Rico, and the Virgin Islands operate their own OSHA-approved safety and health program. For a list of all of the states and further information, please visit OSHA's State Occupational Safety and Health Plans page at [www.osha.gov/dcsp/osp/index](http://www.osha.gov/dcsp/osp/index).



# For More Information

## Resources on Chemical Exposures in Nail Salons

Nail Technicians' Health and Workplace Exposure Controls, NIOSH Workplace Safety and Health Topics, [http://www.cdc.gov/niosh/topics/manicure/?s\\_cid=3ni7d2fb082020111130am](http://www.cdc.gov/niosh/topics/manicure/?s_cid=3ni7d2fb082020111130am). Lists research and publications helpful to preventing injuries and illnesses while working in nail salons.

Controlling Chemical Hazards During the Application of Artificial Fingernails, NIOSH (Publication No. 99-112), <http://www.cdc.gov/niosh/docs/99-112/>. Describes how workers can prevent some of the potentially harmful health effects of applying artificial fingernails.

Tips on Worker Safety, Labor Occupational Health Program (LOHP) and California Healthy Nail Salon Collaborative. Provides general tips for staying safe and healthy while working in nail salons (English) (Vietnamese).

Safety and Health Hazards in Nail Salons, Oregon OSHA Fact Sheet Plus, [http://www.orosha.org/pdf/pubs/fact\\_sheets/fs28.pdf](http://www.orosha.org/pdf/pubs/fact_sheets/fs28.pdf). Describes the potential hazards of chemicals used in nail salons and what workers and nail salon owners can do to minimize exposure.

How to Be Safe at Work, Oregon Healthy Nail Salon Collaborative, <http://www.cbs.state.or.us/osh/pdf/pubs/4783e.pdf>. Gives tips on how to prevent overexposure to chemicals in nail salons.

Summary of Data and Findings from Testing of a Limited Number of Nail Products, California Environmental Protection Agency, Department of Toxic Substances Control, [http://www.dtsc.ca.gov/PollutionPrevention/upload/NailSalon\\_Final.pdf](http://www.dtsc.ca.gov/PollutionPrevention/upload/NailSalon_Final.pdf). Report assessing chemical composition of a limited assortment of nail salon products.

Understanding the Toxic Trio: Protecting Yourself at Work, California Healthy Nail Salon Collaborative, [http://www.cahealthynailsalons.org/wp-content/uploads/2010/07/Toxic\\_Trio\\_EN\\_March2012.pdf](http://www.cahealthynailsalons.org/wp-content/uploads/2010/07/Toxic_Trio_EN_March2012.pdf). This brochure shares tips on how to protect yourself from the Toxic Trio at work.

Safe Nail Salon Training, Boston Public Health Commission, [http://www.bphc.org/programs/cib/environmentalhealth/environmentalhazards/safenailsalons/Forms\\_Documents/2010\\_Safe\\_Nail\\_Salon\\_Training-English.pptx](http://www.bphc.org/programs/cib/environmentalhealth/environmentalhazards/safenailsalons/Forms_Documents/2010_Safe_Nail_Salon_Training-English.pptx). English language training presentation that teaches nail salon owners and workers how to recognize workplace hazards, protect health, make improvements to eliminate hazards, and properly use and store hazardous chemicals (English) (Vietnamese).

Safe Nail Salons: Keeping You and Your Customers Healthy, Boston Public Health Commission, [http://www.youtube.com/watch?v=PksAPhmm15M&feature=player\\_embedded](http://www.youtube.com/watch?v=PksAPhmm15M&feature=player_embedded). Describes nail salon health and safety measures in video format (in Vietnamese with English subtitles).

Healthy Practices for Nail Salons, King County Local Hazardous Waste Management Program, <http://www.lhwmp.org/home/health/nail-salons.aspx>. Displays methods for improving health and safety in nail salons.

Will You Try These Ways to Protect Your Customers and Your Health?, King County Local Hazardous Waste Management Program, Environmental Coalition of South Seattle, and Community Coalition for Environmental Justice, [http://www.lhwmp.org/home/health/documents/Final\\_ENGweb.pdf](http://www.lhwmp.org/home/health/documents/Final_ENGweb.pdf). Gives a brief overview of several measures to protect nail salon workers' health.

California Health Nail Salon Collaborative, <http://www.cahealthynailsalons.org/>. The California Healthy Nail Salon Collaborative's mission is to improve the health, safety, and rights of the nail and beauty care workforce to achieve a healthier, more sustainable, and just industry. This website lists research and outreach publications related to its mission.

Oregon Collaborative for Healthy Nail Salons, Oregon Collaborative for Healthy Nail Salons, <http://www.oregonhealthynailsalons.org/>. Provides information and outreach publications related to its mission of improving the workplace health of nail salon workers.

### Resources on How to Prevent Muscle Strains (Ergonomic Hazards)

Ergonomic Basics for Nail Salon Professionals, International Nail Technicians Association and Nail Manufacturers Council of the Professional Beauty Association, [http://files.nailsmag.com/Handouts/INTA\\_NMC\\_ErgonomicBasics.pdf](http://files.nailsmag.com/Handouts/INTA_NMC_ErgonomicBasics.pdf). Gives basic tips on how to prevent aches and pains while working in nail salons.

Ergonomics Safety and Health Topics Page, OSHA, <http://www.osha.gov/SLTC/ergonomics/index.html>. Gives information about ergonomic hazards at work and how to reduce them.

Ergonomics and Musculoskeletal Disorders, NIOSH Workplace Safety and Health Topics, <http://www.cdc.gov/niosh/topics/ergonomics>. Gives information about ergonomic hazards at work and how to reduce them.

## Resources on How to Prevent Exposure to Biological Hazards

Bloodborne Pathogens Safety and Health Topics Page, OSHA. <http://www.osha.gov/SLTC/bloodbornepathogens>. Gives information on the hazards of bloodborne diseases and how to prevent infection.

Bloodborne Infectious Diseases: HIV/AIDS, Hepatitis B, and Hepatitis C, NIOSH Workplace Safety and Health Topics, <http://www.cdc.gov/niosh/topics/bbp/>. Gives information on specific bloodborne diseases and how to prevent exposure.

Selected EPA-Registered Disinfectants, EPA, <http://www.cdc.gov/niosh/topics/bbp/>. Lists EPA-registered disinfectants that are effective against certain bloodborne diseases.

## OSHA Worker Resources

OSHA's Page for Workers, <http://www.osha.gov/workers.html>. Gives information on workers' rights.

OSHA Regional and Area Offices, <http://www.osha.gov/html/RAMap.html>. Gives contact information for OSHA Regional and Area Offices.

OSHA-Approved State Plans, <http://www.osha.gov/dcsp/osp/index.html>. Lists states with their own occupational safety and health programs, standards and policies.

## NIOSH Health Hazard Evaluation Program

### Getting Help with Health Hazards

The National Institute for Occupational Safety and Health (NIOSH) is a federal agency that conducts scientific and medical research on workers' safety and health. At no cost to employers or workers, NIOSH can help identify health hazards and recommend ways to reduce or eliminate those hazards in the workplace through its Health Hazard Evaluation (HHE) Program.

Workers, union representatives and employers can request a NIOSH HHE. An HHE is often requested when there is a higher than expected rate of a disease or injury in a group of workers. These situations may be the result of an unknown cause, a new hazard, or a mixture of sources. To request a NIOSH Health Hazard Evaluation go to [www.cdc.gov/niosh/hhe/request.html](http://www.cdc.gov/niosh/hhe/request.html). To find out more about the Health Hazard Evaluation Program:

- Call (513) 841-4382, or to talk to a staff member in Spanish, call (513) 841-4439; or
- Send an email to [HHERequestHelp@cdc.gov](mailto:HHERequestHelp@cdc.gov).

For more information



U.S. Department of Labor  
[www.osha.gov](http://www.osha.gov) (800) 321-OSHA (6742)